

PBM MARINER

The PBM Mariner never achieved the popularity of the PBX Catalina. Martin's PBM Mariner offered considerably greater military capability at the expense of increased complexity. Unlike the PBX, which had relatively few problems in service, the PBM suffered from a number of problems, many of them related to the engine. These were finally overcome when the more powerful P&W R-2800s replaced the Wright R2600s in 1944.

The Navy contracted for the XPBM-1 in June 1937. Prior to this time, Martin had flown a quarter scale, piloted "flying model," the Martin 162A, to explore hydrodynamic and aerodynamic characteristics. The XPBM-1 first flew early in 1939 but, in spite of the testing with the 162A, experienced problems both on the water and in flight. Gull wings, twin tails and retractable tip floats were its most distinguishing features. Hull redesign in 1940 and addition of dihedral to the horizontal tail, resulting in the vertical surfaces being canted inward, were major changes introduced to correct the problems in the XPBM-1. They were incorporated in the 20 PBM-1s, which followed. The first of the 1s to enter the fleet was assigned to VP-55 in September 1940.

Along with the PBM-1s, one XPBM-2 was ordered-modified to be a catapult-launched long-range patrol seaplane. While tests were satisfactory, the concept was not pursued.

The next service aircraft were the 3 series, delivered from 1942 through mid-1944. Initially delivered as PBM-3s, they featured improved armament and engines, and could be easily recognized by the fixed wing-tip floats replacing the retractable floats of the 1s. Many of the early 3 series were converted to unarmed 3R transports. 3C patrol planes went to fleet squadrons, followed by stripped 3S ASW versions and, finally, 3Ds with improved R-2600 engines. Radar had been added in a large radome behind the cabin, starting with the 3Cs. Improved versions of radar were used as they became available.

With the R-2800 engine, the subsequent PBM-5 series was destined for service long after WW II. Initial 5s were followed by 5Es with improved radar, and in the postwar period a limited number of 5Gs were delivered with a new radar in a teardrop radome. A prototype amphibian version of the 5 was proposed in April 1944, but was not flown until December 1945. Thirty-six were produced before production stopped in 1949. Up to that time, 1,366 Mariners had been built.

Improvements in the 5 series led to ASW PBM-5S conversions starting late in 1949, while the 5As were converted to unarmed transports. Both models served worldwide well into the Fifties, the 5Ss being supplanted by 5S2s with updated equipment, before the last fleet squadron, VP-50, relinquished them for P5M Marlins in June 1956. Individual Mariners continued in Navy service to meet special needs for a few more years, the last one flying being a hydro-ski test aircraft. Mariners were also transferred and served with the Coast Guard and several foreign countries.

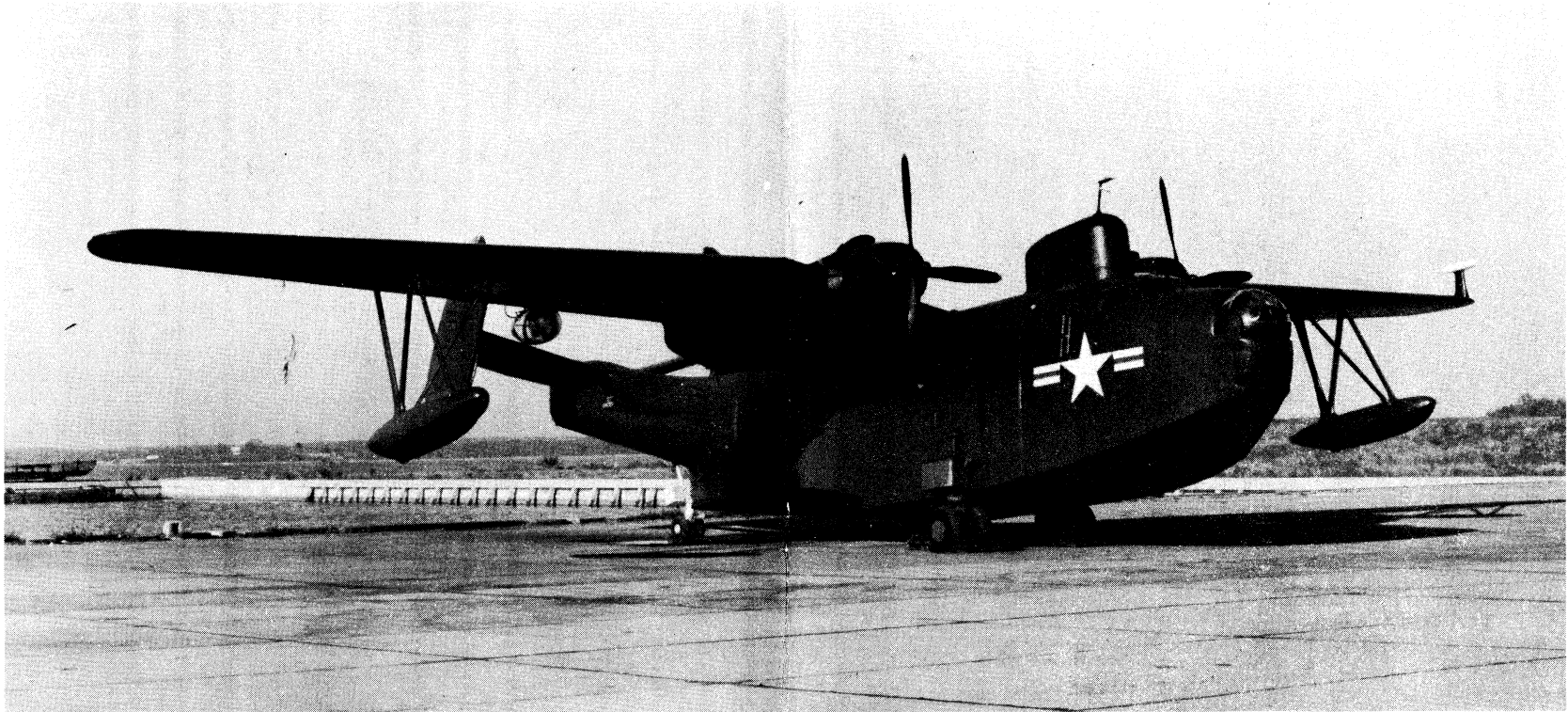

STANDARD AIRCRAFT CHARACTERISTICS

PBM-5S "MARINER"

MARTIN

15

Standard Aircraft Characteristics NAVAER 1335A (REV. 1-49)

BUREAU OF AERONAUTICS
NAVY DEPARTMENT

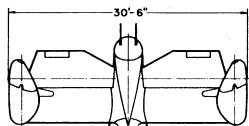

WING AREA-1408 SQ. FT.
WING SECTION-N.A.C.A.
23020-23010
M.A.C.-156.7"
PROP-CURTISS ELECTRIC
BLADE DES. NO. 836-17C2-0
MAIN HULL DISPL.
319,500 LBS.
WING TIP FLOATS DISPL.
7,340 LBS. TOTAL
ASPECT RATIO 9.9

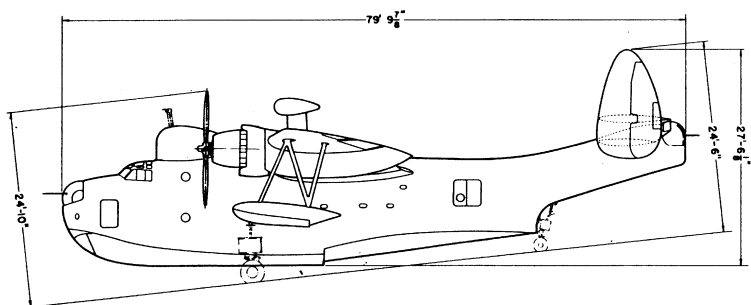
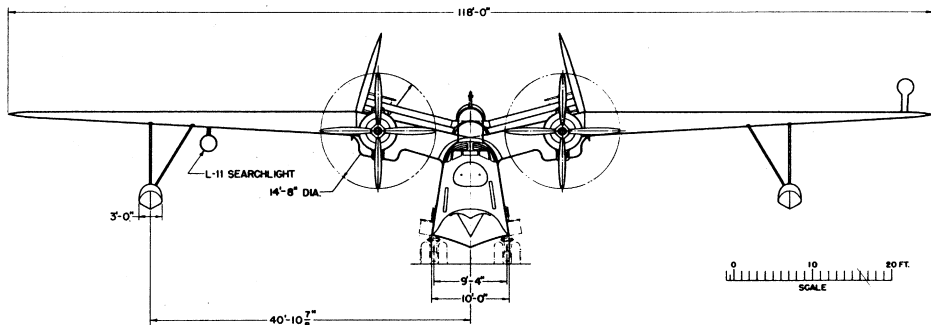
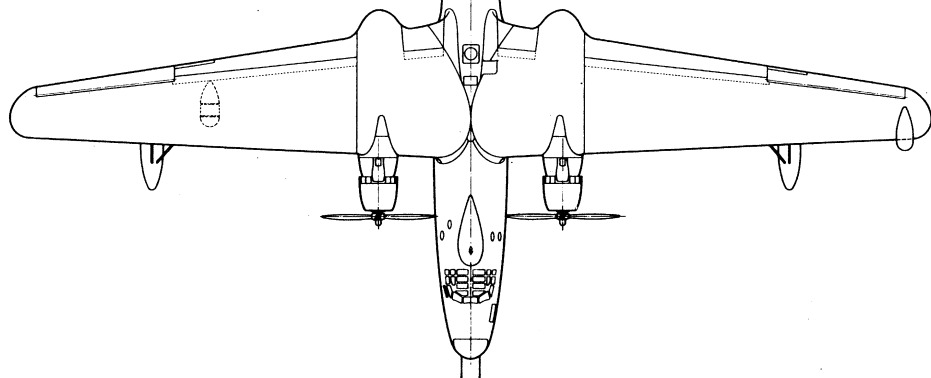

DESCRIPTIVE ARRANGEMENT

BUREAU OF AERONAUTICS
NAVY DEPARTMENT

- ARMOR PLATE
- ▨ SELF-SEALING TANKS
- ⊠ NON SELF-SEALING TANKS

PROTECTION

- | | |
|-----------------------|-----------|
| 1. BOW TURRET | 143 LBS. |
| 2. PILOT & CO-PILOT | 183 LBS. |
| 3. FLIGHT ENGINEER | 226 LBS. |
| 4. FUEL TRUNKS | 44 LBS. |
| 5. TAIL TURRET | 106 LBS. |
| 6. SELF-SEALING CELLS | 1257 LBS. |

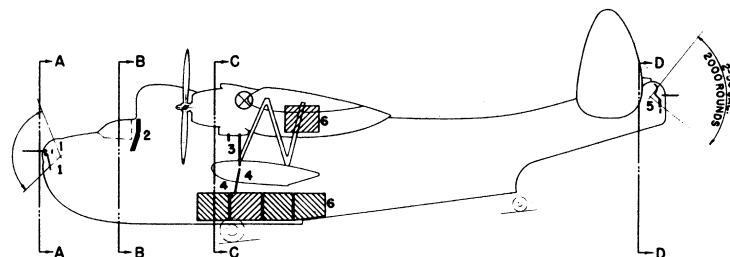
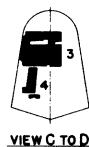
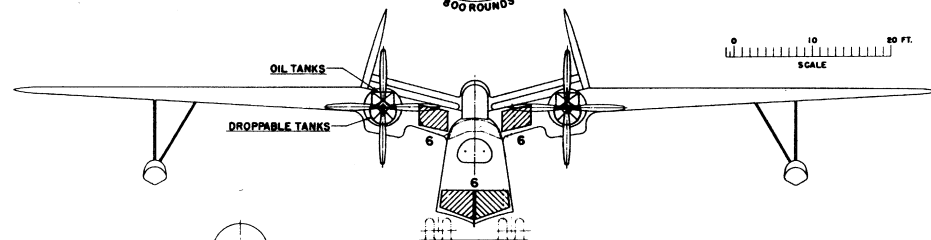
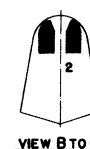
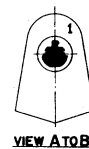
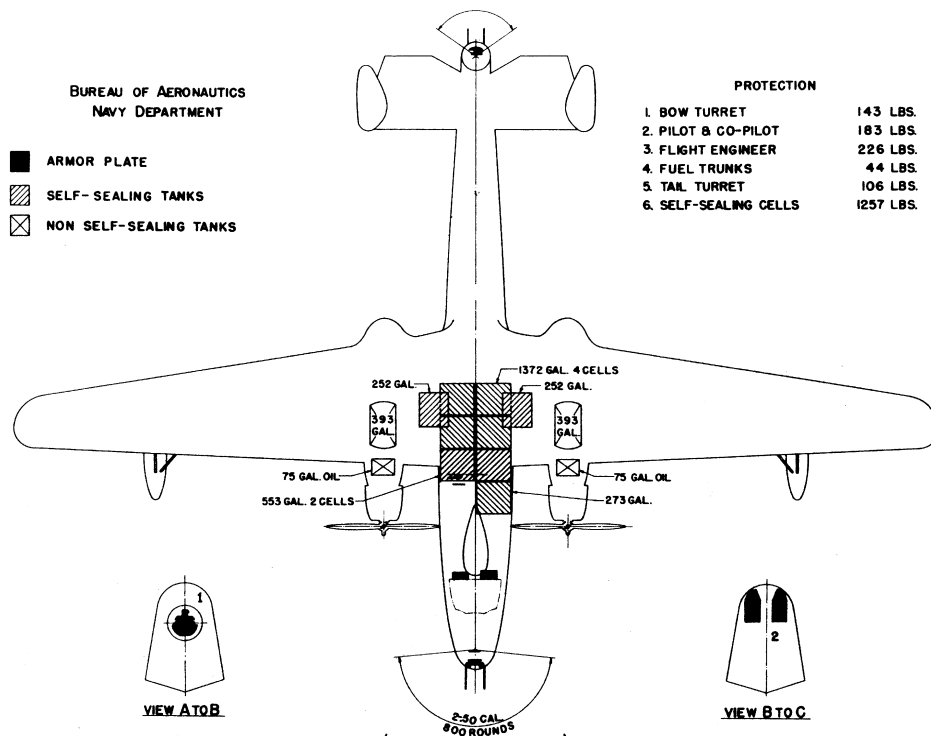

ARMAMENT & TANKS

16
Standard Aircraft Characteristics NAVAER 13358 (REV. 1-49)

MISSION AND DESCRIPTION

The PBM-5S is a version of the PBM-5 seaplane, as modified for anti-submarine warfare. It is capable of operating from advanced seadromes and other areas where landplane operations are not feasible.

The hull is divided into five water-tight compartments by bulkheads provided with water-tight doors. The plane can be equipped with JATO for quick take-offs in small areas and rough water.

It normally carries a crew of ten.

DIMENSIONS

WING AREA.....1,408 sq. ft.
SPAN.....118' - 0"
LENGTH.....79' - 10"
HEIGHT*.....24' - 10"
TREAD.....10' - 0"
M.A.C.....13' - 1"

* Height of airplane on beaching gear.

WEIGHTS

Loadings	Lbs.	L.F.
EMPTY.....	35,500.....	
BASIC.....	36,700.....	
DESIGN.....	56,000..	2.4
COMBAT.....	51,105..	2.6
MAX.T.O. (Smooth).....	60,300..	2.2
(Rough).....	48,000..	2.9
MAX.LD. (Smooth).....	60,300.....	
(Rough).....	48,000.....	

All weights are actual.

FUEL AND OIL

Gals.	No. Tanks	Location
504	2	Wing, S.S.
2,198	7	Hull, S.S.
786	2	Bomb Bay (Drop)

FUEL GRADE.....100/130
FUEL SPEC.....AN-F-48

OIL

CAPACITY (Gals.).....150
GRADE.....1120-1100
SPEC.....AN-0-8

ELECTRONICS

LF-HF-VHF.....AN/ARC-1,-5
COMPASS...SCR-269-F, AN/ARN-7
TRANSMITTER.....AN/ART-13
MARKER BEACON.....AN/ARN-8
ALTIMETER.....AN/APN-1
IFF.....AN/APX-2,-6,-8
SEARCH RADAR...AN/APS-2F,-15A
NAVIG.....AN/APN-4
ECM...AN/APA-11,-38, AN/APR-4
SONOBUOY REC.....AN/ARR-31
SEARCHLIGHT.....L-11
MAD.....AN/ASQ-1
WIRE RECORDER.....13-A-3-J

POWER PLANT

NO. & MODEL.....(2) R-2800-34
MFR.....Pratt & Whitney
SUPERCH.....1 Stage, 2 Speed
PROP. GEAR RATIO.....0.450
PROP. MFR.....Curtiss
PROP. DES. NO.....836-17C2-0
NO. BL./DIA.....4/14'-8"

RATINGS

	Bhp @	Rpm @	Alt.
T. O.	2,100	2,800	S. L.
MIL.	2,100	2,800	3,000'
	1,700	2,800	16,000'
NORM.	1,700	2,600	8,500'
	1,500	2,600	18,500'

SPEC. NO. N-8081
(SEE NOTE)

ORDNANCE

GUNS

No.	Size	Location	Rds.
2	.50 Cal.	Nose Tur.	800
2	.50 Cal.	Tail Tur.	2000

Mark 18-4 Gunsights in Turrets

BOMBS

Type	Size	Location	No.
Bomb	100#	Bomb Bay	12
Bomb	1,000#	Bomb Bay	8
Bomb	1,600#	Bomb Bay	8
D.B.	325#	Bomb Bay	8
Mine	Mk. 26-1	Bomb Bay	8
Mine	Mk. 13	Bomb Bay	4
	or 13-5		
Mine	Mk. 24	Bomb Bay	4

Mark 23-7 Bombsight

FIRE CONTROL

Bombing Equip.....AN/APA-5A
MAX. BOMB LOAD....12,800 lbs.

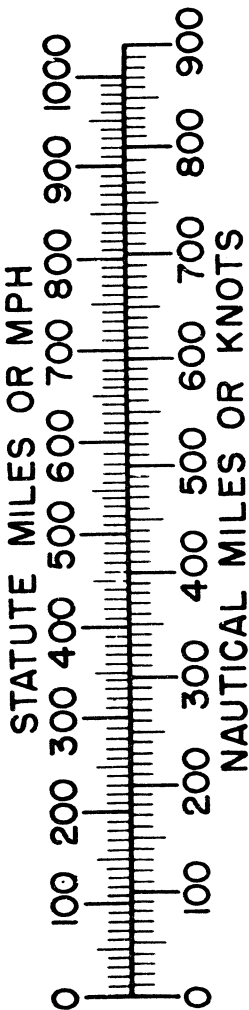

PERFORMANCE SUMMARY

LOADING CONDITION		(1) ASW 8 - 325# Depth Charges		
TAKE-OFF WEIGHT	lbs.	60,190		
Fuel	lbs.	16,212		
Bombs	lbs.	2,600		
Wing/Power Loading (A) lbs/sq.ft; lbs/bhp.		42.7/20.0		
Stall Speed--Power off	kn.	84.1		
Stall Speed--Power off - No Fuel	kn.	71.9		
Stall Speed--Power on	kn.	72.1		
Maximum Speed/Alt (B)	kn/ft.	178/9,500		
Take-off Distance, deck -- calm	ft.	--		
Take-off Distance, deck	kn.	ft.		
Take-off Time	sec.	55.6		
Rate of climb -- sea level (B)	ft/min.	590		
Service Ceiling (B)	ft.	20,800		
Time-to-climb 10,000 ft. (B)	min.	18.6		
Time-to-climb 20,000 ft. (B)	min.	56.4		
Combat Range/V av 1,500 ft.	n.mi./kn.	1,880/118		
Combat Radius/V av (ASW-1)	ft. n.mi./kn.	750/118		
LOADING CONDITION		(2) COMBAT	(3) COMBAT	
GROSS WEIGHT	lbs.	51,105	51,105	
Engine power		Military	Normal	
Fuel	lbs.	9,727	9,727	
Bombs/Tanks		None	None	
Max. speed at sea level	kn.	193	172	
Max. speed/Alt	kn/ft.	200/18,000	191/19,200	
Combat speed/Alt	kn/ft.	196/1,500	174/1,500	
Rate of climb SL	ft/min.	1,460	910	
Ceiling for 500 fpm R/C	ft.	21,100	19,200	
Time-to-climb/Alt.	min/ft.	21.3/20,000	--	

NOTES

- (A) BHP at Maximum Critical Altitude
 (B) Normal BHP

Performance is based on flight test of the PBM-5 airplane.

 Range and radius are based on flight test fuel consumption data of the PBM-5 airplane increased by 5%.

Airplane could not be stalled in these configurations because of insufficient elevator control.
 Minimum speeds shown.

SPEED

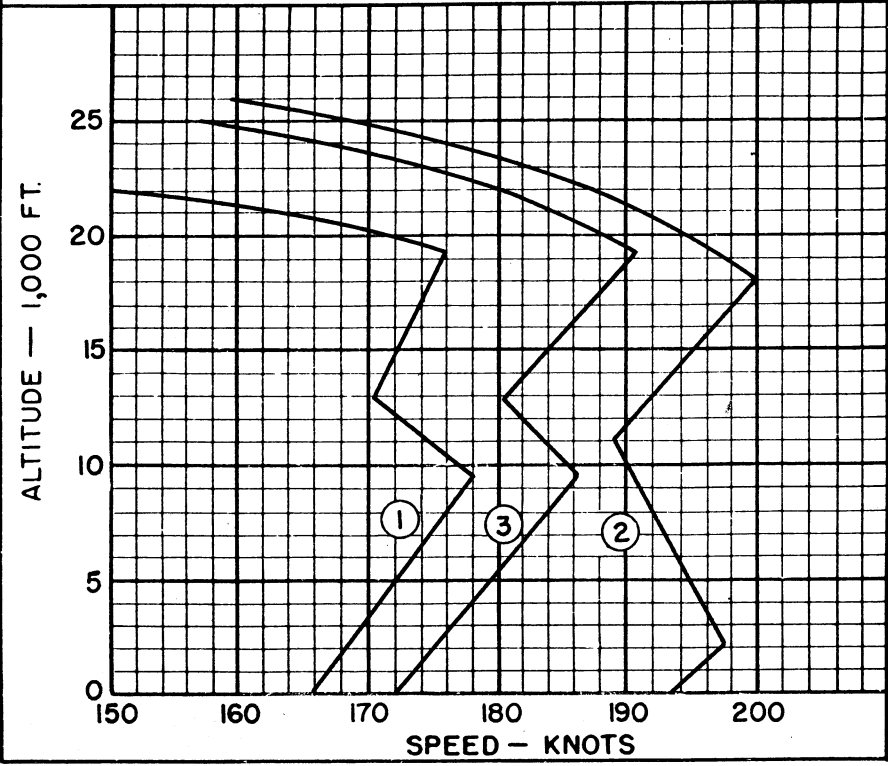

CLIMB

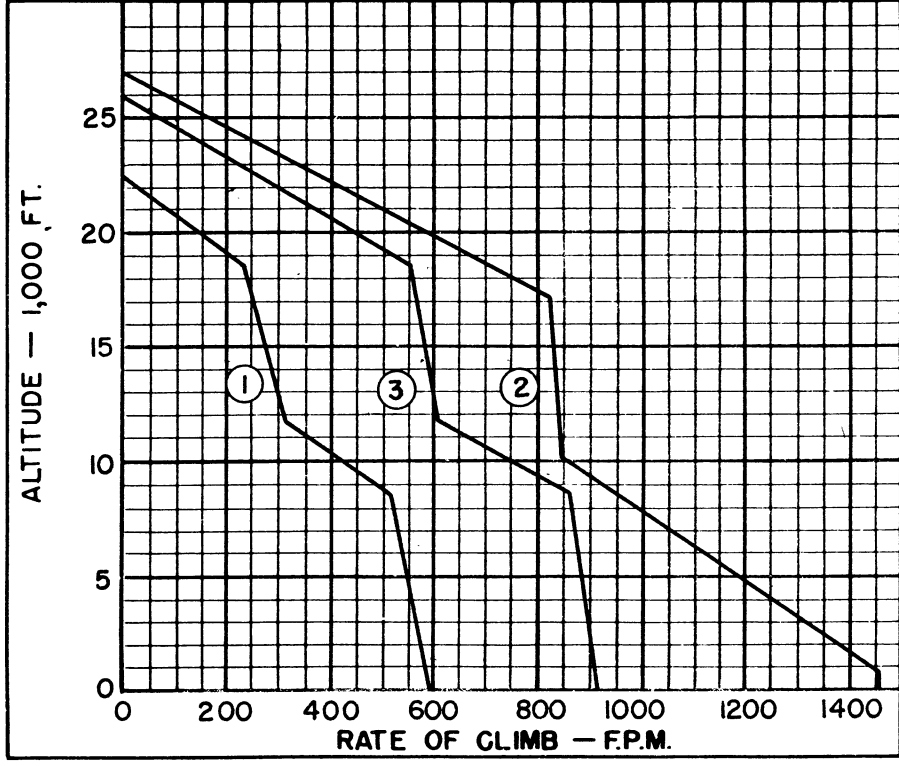

TAKE-OFF

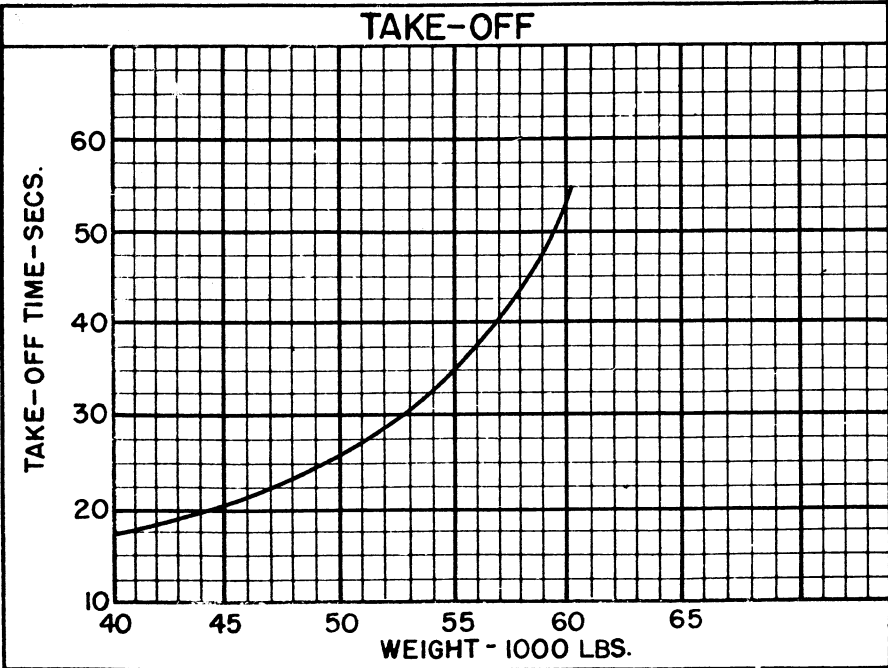

COMBAT RANGE

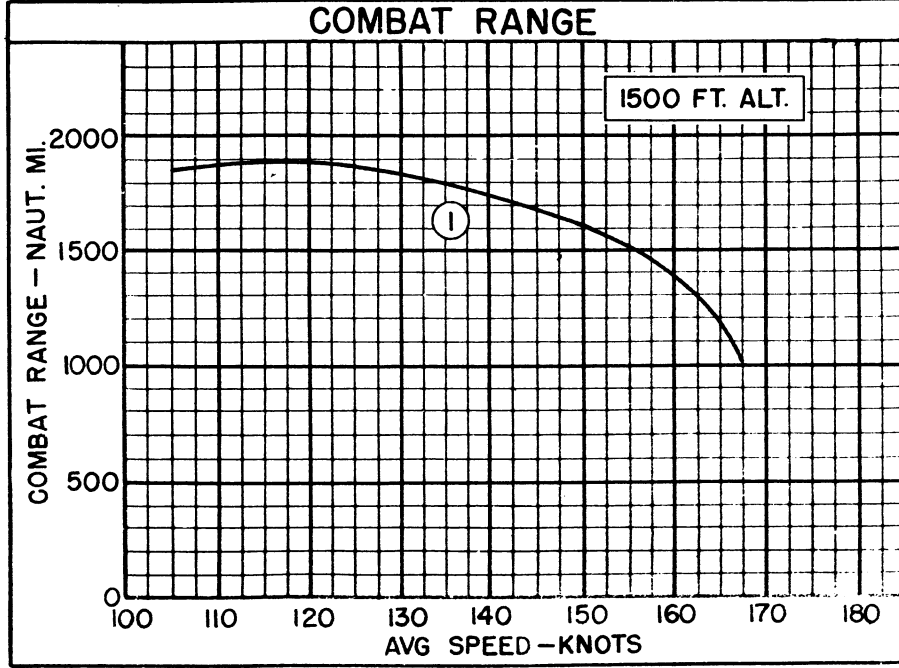

○ LOADING CONDITION COLUMN NUMBER

NOTES

GENERAL ASW PATROL PROBLEM NO. ASW-1

COMBAT RADIUS = 40% of combat range at 1,500 ft. altitude.

Take-off and military power are based on the use of AN-F-48 115/145 fuel resulting in 2300 Bhp at 2800 Rpm at Sea Level.

The following engine ratings from flight test of the PBM-5 airplane were used in preparation of performance data:

	Bhp	@	Rpm	@	Alt.
NORMAL	1,700		2,600		S. L.- 8,600
	1,500		2,600		11,800-18,600

With port engine inoperative, port propeller feathered, cowl flaps one-half open and oil cooler flaps fully open, the maximum gross weight at which 1,000 feet altitude can be maintained with NRP is 48,700 pounds.

20

Standard Aircraft Characteristics NAVAER 1335F (REV. 1-49)